

M/s COSMOS CLEANING SYSTEMS, BANGALORE	PROPOSED BAGMANE ARGON AT BANGALORE	
	CLIENT: M/S BAGMANE DEVELOPERS PVT LTD. ARCHITECTS: M/S GENSLER, BANGALORE FAÇADE CONSULTANTS: M/S FAÇADE TECHNIK, BANGALORE	
PROJ/DESIGN STR/4/2022	STRUCTURAL CALCULATIONS FOR THE PROPOSED MS FRAMEWORK FOR THE MOVEABLE UNIT FIXED TO RCC WITH MS HIGH STRENGTH EYE BOLTS, STABILITY FOR FAÇADE CLEANING APPLICATIONS.	NOV 2022

INDEX SHEET

- A. CODES AND SPECIFICATIONS.
- B. MATERIAL SPECIFICATIONS.
- C. PROJECT SUMMARY SHEET
- D. DESIGN CRITERIA AND LOADING ASSUMPTIONS.
- E. STABILITY CALCULATIONS FOR THE MS FRAMEWORK AND MS HIGH STRENGTH EYE BOLTS , MS BASE PLATE, WELDS FIXED TO THE RCC FOR FAÇADE CLEANING APPLICATIONS.
- F. STAAD-III ANALYSIS RESULTS AND PLOTS.
- G. REFERENCE DRAWINGS AND DOCUMENTS.
- A. CODES AND SPECIFICATIONS

The Structural calculations were Performed in accordance with the following codes or specifications mentioned in the Tender document.

- IS 800 - 2007: Indian code for Structural steel design
- IS 806-1968 : Indian code for Tubular steel structures Design
- Torsteel HandBook for Structural Steel Design.

B. MATERIAL SPECIFICATIONS

- STEEL TUBES OF GRADE YST 240 OF APPROVED MAKE AS PER IS 4923.
- HIGH STRENGTH MS EYE BOLTOF GRADE C45/EN8

M/s COSMOS CLEANING SYSTEMS, BANGALORE	PROPOSED BAGMANE ARGON AT BANGALORE	
	CLIENT: M/S BAGMANE DEVELOPERS PVT LTD. ARCHITECTS: M/S GENSLER, BANGALORE FAÇADE CONSULTANTS: M/S FAÇADE TECHNIK, BANGALORE	
PROJ/DESIGN STR/4/2022	STRUCTURAL CALCULATIONS FOR THE PROPOSED MS FRAMEWORK FOR THE MOVEABLE UNIT FIXED TO RCC WITH MS HIGH STRENGTH EYE BOLTS, STABILITY FOR FAÇADE CLEANING APPLICATIONS.	NOV 2022

C. PROJECT SUMMARY SHEET

This structural design report is prepared to evaluate the structural performance of the **FOR THE MS FRAMEWORK AND MS HIGH STRENGTH EYE BOLTS , MS BASE PLATE, WELDS FIXED TO THE RCC FOR FAÇADE CLEANING APPLICATIONS** and to ensure the total stability of the entire system.

D. DESIGN CRITERIA AND LOADING ASSUMPTIONS.

- The maximum permissible deflection of the MS members are taken as $\text{Span}/300$ as per IS 800-2007.

FACADE ACCESS MOVABLE SYSTEM

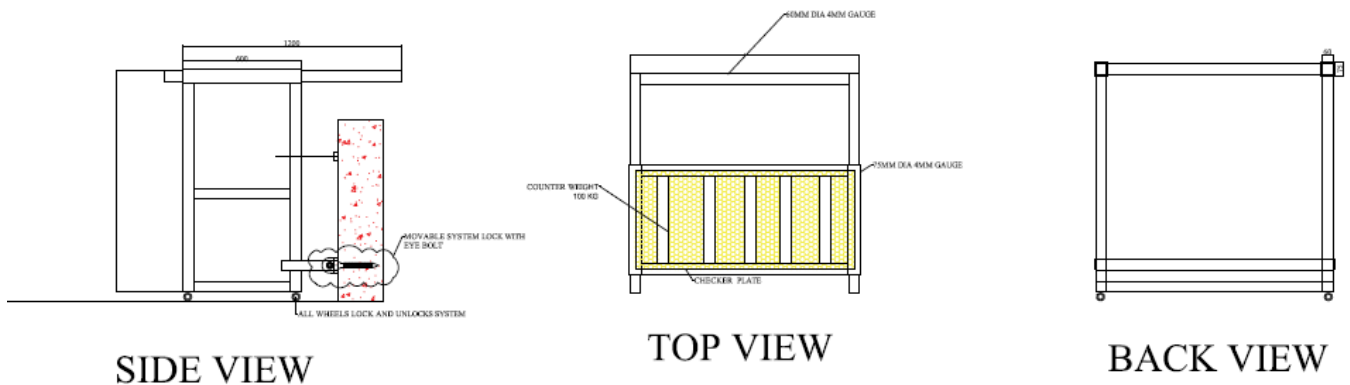

M/s COSMOS CLEANING SYSTEMS, BANGALORE	PROPOSED BAGMANE ARGON AT BANGALORE	
	CLIENT: M/S BAGMANE DEVELOPERS PVT LTD. ARCHITECTS: M/S GENSLER, BANGALORE FAÇADE CONSULTANTS: M/S FAÇADE TECHNIK, BANGALORE	
PROJ/DESIGN STR/4/2022	STRUCTURAL CALCULATIONS FOR THE PROPOSED MS FRAMEWORK FOR THE MOVEABLE UNIT FIXED TO RCC WITH MS HIGH STRENGTH EYE BOLTS, STABILITY FOR FAÇADE CLEANING APPLICATIONS.	NOV 2022

E. STABILITY CALCULATIONS FOR THE MS FRAMEWORK AND MS HIGH STRENGTH EYE BOLTS , MS BASE PLATE, WELDS FIXED TO THE RCC FOR FAÇADE CLEANING APPLICATIONS.

DESIGN LOADS TO BE CONSIDERED FOR THE STRUCTURAL ANALYSIS OF THE MS FRAMEWORK.

- Design Load = 500 kgs

The MS framework is made up of Vertical Column for a height of 1.216m of SHS 60 x 60 x 3mm thk spaced at 1.216m and Main members along 1.2m of SHS 60 x 60 x 3mm thk and for 600mm it is of MS Box of 72 x 72 x 4mm thk and connecting members of SHS 60 x 60 x 3mm thk and All steel tubes are of grade yst 240 as per IS 4923 of Tata/Jindal/Approved Make.

The self weight of the frame is considered in the STAAD-III analysis and the loading assumptions and Max results are tabulated as follows

- With this loading conditions The MS Framework is analysed
- using STAAD-III and Results are computed as follows.
- Maximum Bending stress in the framework as per STAAD-III
Analysis = 1187kg/sqcm < 1655kg/sqcm
- Maximum Combined Bending stress in the framework as per STAAD-III
Analysis = 1187kg/sqcm < 1655 kg/sqcm
- Maximum shear stress in the framework as per STAAD-III
- Analysis = 67kg/sqcm < 1100 kg/sqcm
- Maximum Deflection as per STAAD-III Analysis along 1.2m span = 3.33mm.
- Permissible Deflection as per IS 800– 2007: Code of practice for Steel
- in Construction = Span /300 = 1200/300 = 4mm

The MS framework is made up of Vertical Column for a height of 1.216m of SHS 60 x 60 x 3mm thk spaced at 1.216m and Main members along 1.2m of SHS 60 x 60 x 3mm thk and for 600mm it is of MS Box of 72 x 72 x 4mm thk and connecting members of SHS 60 x 60 x 3mm thk and All steel tubes are of grade yst 240 as per IS 4923 of Tata/Jindal/Approved Make is safe in Bending stress, Shear stress and Deflection criteria.

M/s COSMOS CLEANING SYSTEMS, BANGALORE	PROPOSED BAGMANE ARGON AT BANGALORE	
	CLIENT: M/S BAGMANE DEVELOPERS PVT LTD. ARCHITECTS: M/S GENSLER, BANGALORE FAÇADE CONSULTANTS: M/S FAÇADE TECHNIK, BANGALORE	
PROJ/DESIGN STR/4/2022	STRUCTURAL CALCULATIONS FOR THE PROPOSED MS FRAMEWORK FOR THE MOVEABLE UNIT FIXED TO RCC WITH MS HIGH STRENGTH EYE BOLTS, STABILITY FOR FAÇADE CLEANING APPLICATIONS.	NOV 2022

**CHECK FOR THE MS HIGH STRENGTH EYE BOLTS STABILITY FOR FAÇADE
CLEANING APPLICATIONS**

**THE MS HIGH STRENGTH EYE BOLT OF M16 X 150 L OF C45/EN8 FIXED TO THE
RCC.**

- Design Load as per STAAD-III Analysis = 525kgs
- Tensile stress in the MS Eye Bolt =
- $(525)/3.14/4 \times 1.6 \times 1.6 \times 0.75 = 348\text{Kg/sqcm} < 1000 \text{ kg/sqcm}$
- Allowable Permissible Shear stress in the S.S Bolts = 1000 kg/sqcm
- Tensile stress in the MS Eye Bolt =
- $(525)/3.14/4 \times 1.6 \times 1.6 \times 0.75 = 348\text{Kg/sqcm} < 1500 \text{ kg/sqcm}$
- Where permissible shear and Tensile stress as per IS 800-2007
- Is mentioned as 150 Mpa for Tension , 100Mpa for shear, 300Mpa

**Therefore MS High Eye Strength Bolts of M16 x 150L of C45/ EN8
Grade fixed to the RCC is safe in Tensile & Shear stress criteria.**